

LOOP / PSC / LOAD Tester



CE

1825 LP

1825 LP is the instrument which display the main **system voltage** (V at 0A) of the power utility and calculates the **volt drop** between Line and Neutral as if 16A flowing between Line to Neutral.

1825LP displays the system voltage minus the voltage losses into the Line and Neutral impedances (losses due to the current circulating into these impedances).

The result of this dropped **voltages is displayed as if you had a 16A load** (V at 16A).

This instrument is useful for fault-finding or commissioning of electrical installations.

This new instrument uses a three wires unique principle of operation. 1825 LP displays the **Loop Impedance** between Line and Earth ($Z_L + Z_E = Z_{L-E}$) and **Prospective Short Circuit** between Line and Neutral.

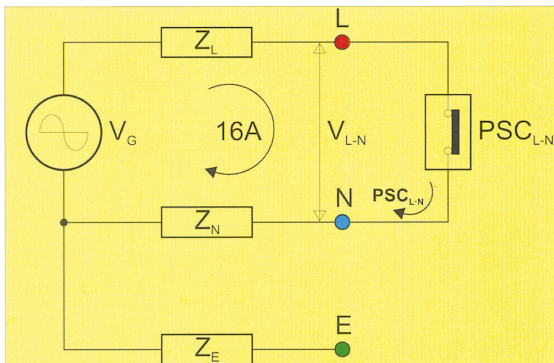

$$V_{L-N} = \text{Main Voltage (with Load=V@16A)}$$

$$Z_L + Z_E = Z_{L-E} = \text{Loop Impedance}$$

$$PSC_{L-N} = \text{Prospective Short Circuit Current (L to N)}$$

$$V_{L-N} = \text{Main Voltage (without Load=V@0A)}$$

FEATURES

- **Microprocessor-controlled.**
- Measures the voltage drop as if 16A was flowing between Line and Neutral.
- Displays voltage without current (V at 0A).
- Display voltage as if 16A flowing between Line and Neutral (V at 16A).
- Loop test for L-E
- PSC between L-N.
- Single one smart push button operation; ON, Scroll through results and menus.
- Checks wiring integrity (LEDs).
- Auto off/auto ranging (software range).
- Combined prospective short circuit current, loop and load tester.
- Display can be customized for large orders.

SPECIFICATIONS

Loop impedance range L-E	0.03-2000Ω (software ctrl)
Test currents in each loop	11.76A at 230V / 50Hz
Voltage measurement L-N	50 to 280V AC (Sine)
Load current for volt drop (L-N)	16A (Calculation)
Neutral wire resistance	(Not available, see 1826 NA)
Line wire resistance & transformer windings	(Not available, see 1826 NA)
PSC current (L-N) max	6kA at 230Vac supply
PSC current (L-E) max	(Not available, see 1826 NA)
Operating voltage	230V±20V at 50Hz Sine

Typical Accuracy

Loop impedance	±5%rdg ± 2dgt
PSC current	±12%rdg ± 5dgt
Voltage	±3%rdg ± 1dgt
Operating-temperature	-10°C to +40°C 80% Max.
-humidity	relative humidity
Dimensions	170(L) x 165(W) x 92(D)mm
Weight (battery included)	Approx. 970g
Power source	1.5V (AA) x 8
Safety standard	EN 61010-1 CAT III 300V EN 61326-1

Accessories	Instruction manual Test leads Shoulder belt Batteries
-------------	--



AL-34B

BET-1800